

Set-up

Learn more at Sparklight.com/selfinstall

Before you begin, please remove modem from all plastic & packaging.

STEP 1 Modem Location

Select the most optimal coaxial cable outlet location for your modem. Note: all cable outlets in your home may not be activated. You may need to try multiple cable outlet locations in order to complete your service activation. **Find additional tips for modem placement on the back page of this guide!**

STEP 2 Coaxial Cable

Connect the coaxial cable from the modem to a cable outlet. Ensure the connections at the outlet and at the back of the modem are finger tight.

 **TIP:** If the modem does not come online after you complete step 5, come back to this step and try a different cable outlet.

STEP 3 Power Cord

Connect the power cord from the modem to a power outlet.

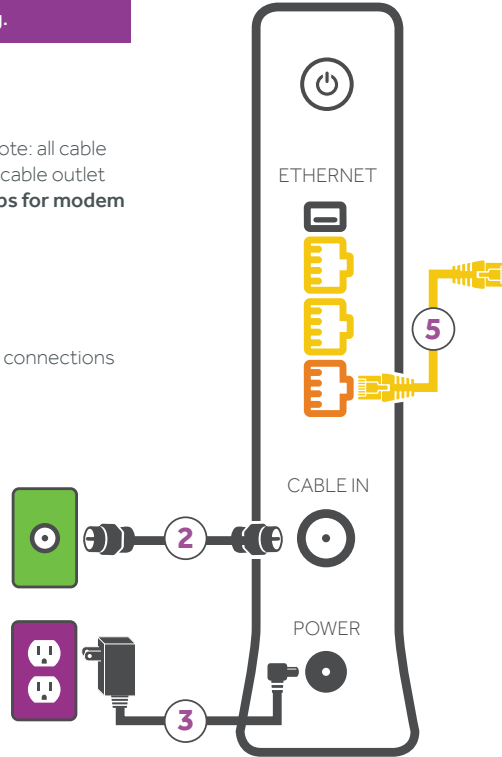

STEP 4 Modem Initialization

Wait for the modem to start (this can take up to 10 minutes). The modem will flash a series of blue, green, and orange lights during start up and will be ready when the front (under glow) light turns on and stays solid white.

 **NOTE:** If the Modem light continues flashing for more than 10 minutes, the cable outlet you are using is **NOT ACTIVE**. You will need to try new coaxial outlet location(s) in your home.

STEP 5 Ethernet Cable (Optional)

Connect the Ethernet cable from the modem to desired devices (computers, smart TVs, gaming consoles, etc.). While an Ethernet connection is optional, it is the only way to guarantee speed.

 **TIP:** The orange port is 2.5G while the yellow ports are 1G. The orange 2.5G port should be used for the primary Ethernet-connected device.

STEP 6 WiFi Connection

Use a WiFi-capable device to connect to your WiFi network using the **Default Wi-Fi network:** and **Password** from the label on the back or bottom of the modem.

Sample Sticker on
Back of Modem

Default Wi-Fi network:
XXXXXXXXXXXX
Password: XXXXXXXXXXXX



On a laptop or desktop computer, open an internet browser. You will be redirected to Sparklight's Welcome page, followed by the Acceptable Use Policy page. **Read** and **acknowledge both notices** to get connected.



24-Hour Support
support.sparklight.com
1-877-692-2253



By opening the package, I acknowledge the following as applicable: I am the Sparklight and credit card account holder or have been authorized to charge the account holder's credit card and accept the following terms on behalf of the account holder. I have received or will request a customer handbook and annual notice, Acceptable Use Policy (AUP), and general terms and conditions which are subject to change and I agree to their terms. I have provided an email address and will receive by email a copy of any applicable service agreement. If I did not provide an email address, I would obtain a copy of the agreement, and whether I do or not, I agree to be bound by the terms of the agreement. I will return or pay the appropriate fee for Sparklight equipment promptly upon termination of service. I authorize Sparklight to charge the indicated credit or debit card if my service or fee payment is ever late.

Tips to Enhance Your WiFi

MODEM PLACEMENT

Place your modem out in the open. Don't position it in a closet, desk or crowded bookshelf. Walls, books and furniture are made of materials that can block some of the WiFi signal. Avoid placing your modem on the ground as most modems are built to broadcast slightly downward – the higher the better!

YOUR WIFI MAY JUST NEED A RESET.

With devices constantly connected to your network, your WiFi modem can slow down if you don't give it a break. To refresh your modem, unplug the power cord, wait 30 seconds, and plug it back in.

OLDER DEVICES MAY NOT BE UP TO SPEED.

Older devices like cell phones, gaming consoles, or tablets that are using WiFi could slow down your whole network. Check the manufacturer sites/settings of your device(s) to ensure that you are running the latest software versions. You can also try disconnecting devices one device at a time to bring back your WiFi speed.

LOOSE CONNECTIONS CAN REALLY SLOW YOU DOWN.

Sometimes the most obvious reason for a slow device is just one push or twist away. Make sure the coaxial connections at your WiFi modem and at the cable outlet are both good and tight.

WiFi ONE

Should your WiFi ever need a boost, WiFi ONE is an advanced WiFi solution that will provide you with enhanced WiFi signal strength to extend and improve the WiFi signal throughout your home. With WiFi ONE, you will receive quality wireless Internet throughout your home – backed by our 100% satisfaction guarantee.

Learn more at Sparklight.com/wifione.



Welcome to your Sparklight Customer Self-Install Kit.

At Sparklight, we understand the importance of connecting you to what matters most. The customer self-install kit allows you to set up service on your schedule with flexibility and ease. Please see easy step-by-step instructions inside and **scan the QR Code to watch our step-by-step video.**

